



PE RESTRAINT **VALVES & FITTINGS**



Personalised service, distribution across Australia, New Zealand and Asia Pacific regions with a comprehensive product range to match, you're in expert hands.



TABLE OF CONTENTS

PE Restraint Joint _____	1
Advantages _____	3
Flange Adaptors _____	4
Couplings _____	5
Resilient Seat Gate Valves _____	6
Notes _____	7

BESTPRACTICE
CERTIFICATION



ISO9001
QUALITY
MANAGEMENT SYSTEM



WaterMark

IAPMO



OceanaMark



WATER SERVICES
ASSOCIATION OF AUSTRALIA



VALVES AND FITTINGS PROVIDING FULL RESTRAINT OF DN125 AND DN180 PE PIPE WITH OPERATING PRESSURES UP TO PN16.

The PE Restraint Joint is an easy and quick installation method for connections between PE pipes as well as PE pipes to Ductile Iron fittings. The advantages of the PE Restraint Joint is that it doesn't require any specialised equipment for installation and can be used in any weather conditions. Tightening the bolts on the End Ring clamps the Grip Ring onto the PE pipe, making a fully restrained connection. The socket uses a lip seal rubber gasket for a complete leak tight connection and only the highest grade of materials are used to ensure maximum corrosion protection.



Advantages of the PE Restraint Joint

- Fully restrained PE pipe
- Quick and easy to install
- Superior corrosion protection
- Can be installed in any weather conditions
- No specialised equipment for installation

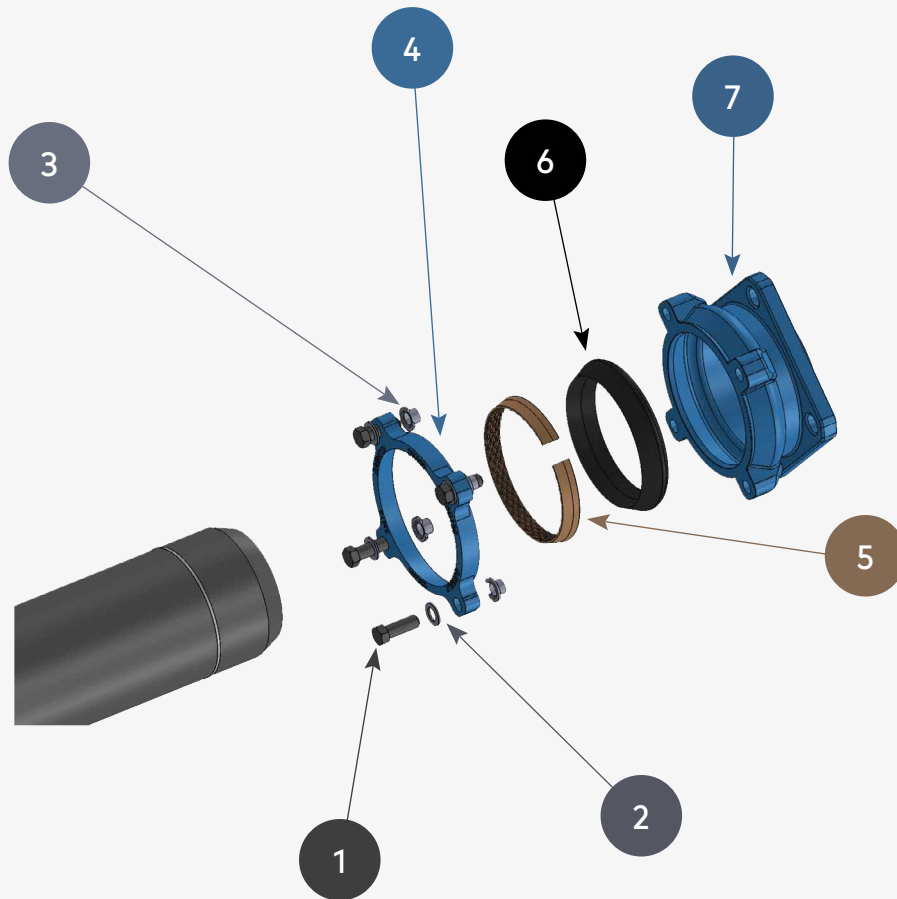

1	BOLTS	Stainless Steel 316, Molybdenum Delta Seal
2	WASHERS	Stainless Steel 316
3	SPACERS	Polypropylene
4	END RING	Ductile Iron FBE Coated
5	GRIP RING	Copper Alloy
6	GASKET	EPDM
7	BODY	Ductile Iron FBE Coated

FLANGE ADAPTORS

Design Advantage

- Push-in socket joint
- Fully restrained connection
- Flanges compliant to AS/NZS 4087



Technical Detail

Range PE DN125/100 and PE DN180/150

Pressure PN10 to PN16 / SDR17 to SDR11

Socket Max 1.5° Deflection

Temperatures 40°C

Applications Suitable for above and below ground installations, potable water, recycled water, waste water, fire and irrigation applications

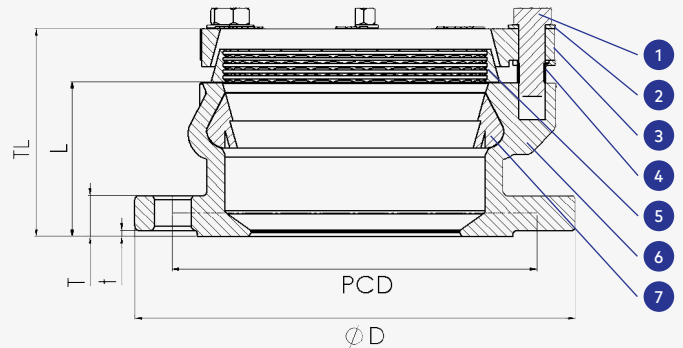

Compliance

- ISO EN 12842 Licence OMK30063
- WSAA PA 1624



NO.	PART	MATERIAL	STANDARD
1	End Ring Bolt	Stainless Steel, MDS*	SS316 ASTM A276
2	Washer	Stainless Steel	SS316 ASTM A276
3	End Ring	Ductile Iron	500-7 AS 1831
4	Spacer	Engineered Plastic	Polypropylene AS 1831
5	Grip Ring	Copper Alloy	C83600 AS 1568
6	Body	Ductile Iron	500-7 AS 1831
7	Socket Gasket	Rubber	EPDM AS 1646

* Molybdenum Delta Seal

PE PIPE END						FLANGE END							
DN PE	PN	L	TL	FASTENERS		DN FL	D	PCD	QTY HOLES	HOLE Ø	FASTENER SIZE	t	T
				SIZE	QTY								
125	16	77	103	M12	4	100	215	178	4	18	M16	3	20
180	16	98	127	M12	4	150	280	235	8	18	M16	3	23



Scan QR Code for Installation Instructions

COUPLINGS

Design Advantage

- Push-in socket joint
- Fully restrained connection



Technical Detail

Range PE DN125 and PE DN180

Pressure PN10 to PN16 / SDR17 to SDR11

Socket Max 1.5° Deflection

Temperatures 40°C

Applications Suitable for above and below ground installations, potable water, recycled water, waste water, fire and irrigation applications

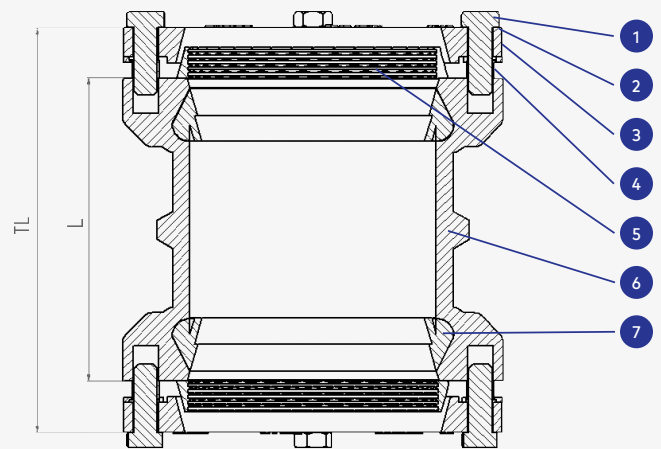

Compliance

- ISO EN 12842 Licence OMK30063
- WSAA PA 1624



NO.	PART	MATERIAL	STANDARD
1	End Ring Bolt	Stainless Steel, MDS*	SS316 ASTM A276
2	Washer	Stainless Steel	SS316 ASTM A276
3	End Ring	Ductile Iron	500-7 AS 1831
4	Spacer	Engineered Plastic Polypropylene	AS 1831
5	Grip Ring	Copper Alloy	C83600 AS 1568
6	Body	Ductile Iron	500-7 AS 1831
7	Socket Gasket	Rubber	EPDM AS 1646

* Molybdenum Delta Seal

DIMENSIONS					
DN	PN	L	TL	FASTENER	
				SIZE	QTY
125	16	134	188	M12	4 X 4
180	16	185	238	M12	4 X 4



RESILIENT SEAT GATE VALVES

Design Advantage

- Push in socket joint
- Fully restrained connection
- Full vulcanized ductile iron encapsulated wedge
- Smooth opening and closing operation
- Full bore waterway



Technical Detail

Range	DN125 and DN180
Pressure	PN10 to PN16 / SDR17 to SDR11
Temperatures	40°C
Applications	Suitable for above and below ground installations, potable water, recycled water, waste water, fire and irrigation applications
Closing	Anti-Clockwise (ACC) / Clockwise Closing (CC)
Options	Handwheel

Compliance

- AS/NZS 2638.2 Licence WM-22535 and OMK22535
- ISO EN 12842 Licence OMK30063
- WSAA PA 1624 / WSAA PA 1517

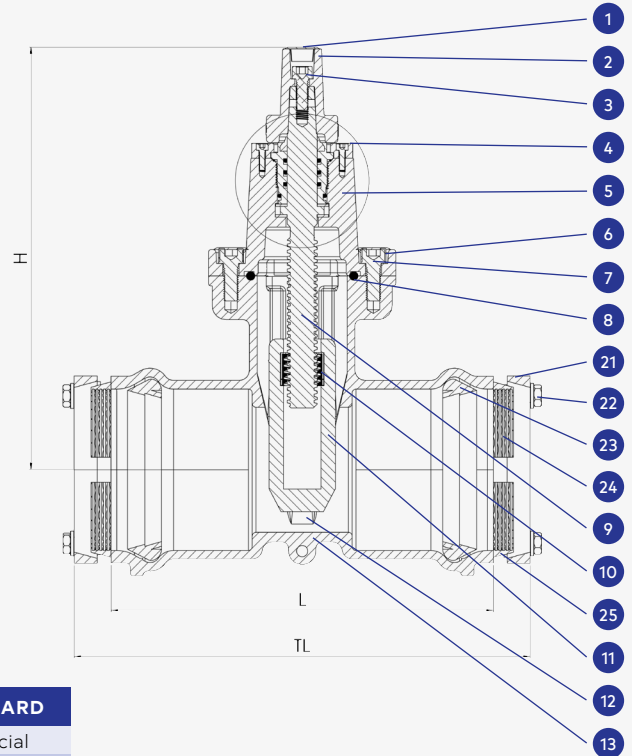

NO.	PART	MATERIAL	STANDARD
1	Dust Cap	Plastic Nylon 66	Commercial
2	Valve Cap	Ductile Iron 500-7	AS 1831
3	Valve Cap Bolt	Stainless Steel SS316	ASTM A276
4	Gland Flange	Stainless Steel SS316	ASTM A276
5	Bonnet	Ductile Iron 500-7	AS 1831
6	Bonnet Bolt Infill	Hot Melt	
7	Bonnet Bolt	Stainless Steel SS316	ASTM A276
8	Bonnet O-Ring	Rubber EPDM	AS 1646
9	Stem	Stainless Steel SS431	ASTM A276
10	Driving Nut	Copper Alloy C83600	AS 1568
11	Wedge	Ductile Iron 500-7 Rubber EPDM	AS 1831 AS 1646
12	Nylon Guide	Engineered Plastic Nylon 66	Commercial
13	Body	Ductile Iron 500-7	AS 1831
14	Scraper Seal	Engineered Plastic Nylon 66	Commercial
15	Gland Flange Bolt	Stainless Steel SS316	ASTM A276
16	Gland O-Ring A	Rubber NBR	AS 1646
17	Gland Nut	Copper Alloy C83600	AS 1568
18	Gland O-Ring B	Rubber NBR	AS 1646
19	Gland O-Ring C	Rubber NBR	AS 1646
20	Thrust Washer	Engineered Plastic Nylon 66	Commercial
21	End Ring	Ductile Iron 500-7	AS 1831
22	End Ring Bolt/Washer	Stainless Steel, MDS*	SS316 ASTM A276
23	Socket Gasket	Rubber EPDM	AS 1646
24	Grip Ring	Copper Alloy C83600	AS 1568
25	Spacer	Engineered Plastic Polypropylene	Commercial
*	Lifting Lugs	Steel Galvanized	Commercial

* Molybdenum Delta Seal

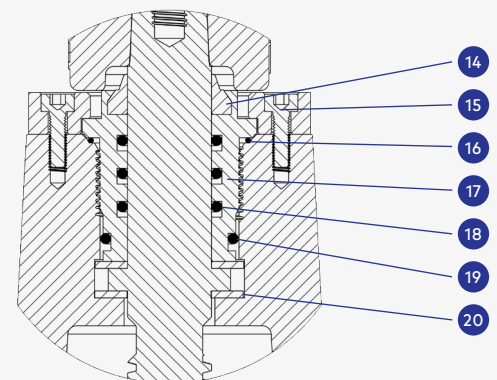

DETAILS			
DN	L	TL	H
100/125	306	362	325
150/180*	394	455	400



Scan QR Code for Installation Instructions



DAEMCO
daemco.com.au 03 9863 6838
2 / 7-9 Clarissa Street, Campbellfield, 3061

**PARTNERING WITH OUR
CUSTOMERS TO DELIVER
END TO END SOLUTIONS**



www.daemco.com.au



VALVES



COUPLINGS



ACCESSORIES



PE DI FITTINGS



COVERS



BANDS

Head Office: Ground Floor. 215 Bell Street, Preston VIC 3072

Phone: +61 3 9863 6838 | Email: enquiries@daemco.com.au

Follow us on **LinkedIn**

©Copyright 2018. All Rights Reserved. Daemco Australia reserve the right to change designs and specifications without notice, warranties for suitability for use, liability or loss, damage or costs incurred relating to this information is excluded.